

freytam

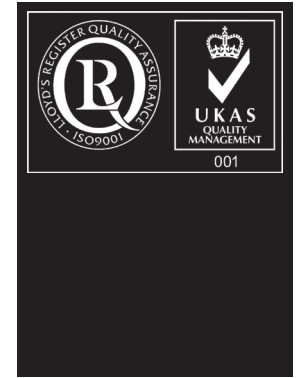

INFORMACIÓN TÉCNICA DE ROSCAS Y ASIENTOS NORMALIZADOS PARA CONEXIONES EMPLEADAS EN INSTALACIONES NEUMÁTICAS Y OLEOHIDRÁULICAS

ROSCA BSP		
Rosca y número de hilos	Diámetro macho mm.	Diámetro tuerca mm.
1/8-28	9,72	8,7
1/4-19	13,2	11,7
3/8-19	16,7	15,15
1/2-14	21	18,8
5/8-14	22,9	20,9
3/4-14	26,4	24,3
1-11	33,24	30,6
1 1/4-11	41,9	39,3
1 1/2-11	47,8	45,15
2-11	59,6	57

ROSCA AMERICANAS					
Diámetro pulgadas	Hilos SAE	Hilos JIC	Hilos PTT	D mm.	d mm.
7/16	20	20	-	11,07	10,00
1/2	20	20	-	12,70	11,60
9/16	18	18	-	14,25	13,00
5/8	18	-	-	15,85	14,70
3/4	16	16	-	19,00	17,60
7/8	14	14	-	22,17	20,50
1-1/16	14	12	-	26,95	25,00
1-5/16	-	12	14	33,30	31,30
1-5/8	-	12	14	41,22	39,20
1-7/8	-	12	14	47,57	45,90
2-1/2	-	12	12	63,45	61,50

ROSCA NPTF Y BSP CÓNICA			
Diámetro nominal pulgadas	Número hilos NPTF	Número hilos BSP	D mm.
1/8	27	28	10,31
1/4	18	19	13,80
3/8	18	19	17,30
1/2	14	14	21,40
3/4	14	14	26,90
1	11 1/2	11	33,30
1-1/4	11 1/2	11	42,40
1-1/2	11 1/2	11	48,40
2	11 1/2	11	60,30

ROSCA MÉTRICA					
	DIN serie L 24° diámetro tubo	DIN serie S 24° diámetro tubo	ROSCA	D mm.	d mm.
	6	-	M12X1,5	12,0	10,5
	8	6	M14X1,5	14,0	12,5
	10	8	M16X1,5	16,0	14,5
	12	10	M18X1,5	18,0	16,5
	-	12	M20X1,5	20,0	18,5
	15	14	M22X1,5	22,0	20,5
	-	16	M24X1,5	24,0	22,5
	18	-	M26X1,5	26,0	24,5
	22	20	M30X2	30,0	27,5
	28	25	M36X2	36,0	33,5
	-	30	M42X2	42,0	39,5
	35	-	M45X2	45,0	42,5
	42	38	M52X2	52,0	49,5

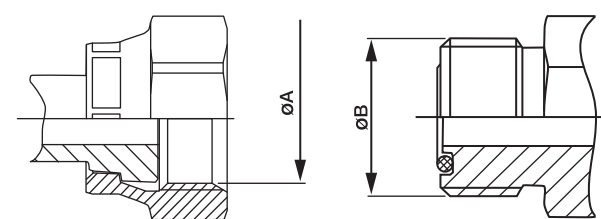

ROSCA ORFS					
D.E. tubo	Tubo D (mm)	Rosca UNF	tamaño	ØA (mm)	ØB (mm)
1/4"	6	9/16-18	-4	13,00	14,20
3/8"	10	11/16-16	-6	15,90	17,50
1/2"	12	13/16-16	-8	19,10	20,60
5/8"	16	1-14	-10	23,80	25,40
3/4"	20	1.3/16-12	-12	28,20	30,10
1"	25	1.7/16-12	-16	34,15	36,50
1.1/4"	32	1.11/16-12	-20	40,50	42,90
1.1/2"	38	2-12	-24	48,80	50,80

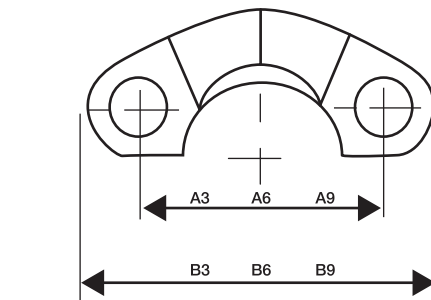

DN	GALGA	BRIDA	A3	B3	C3	A6	B6	C6	A9	B9	C9
12	8	1/2"	38'1	54	6'2	40'5	57	7'2	-	-	-
16/20	10/12	3/4"	47'6	66	6'2	50'8	72	8'3	50'8	70	13'5
25	16	1"	52'4	70	7'5	57'2	81	9'0	57'2	79	13'5
32	20	1.1/4"	58'7	80	7'5	66'7	96	9'8	66'7	94	13'5
40	24	1.1/2"	69'9	94	7'5	79'4	113	12'1	79'4	109	13'5
50	32	2"	77'8	102	9'0	96'8	134	12'1	96'8	133	13'5

3 : 3.000 PSI
6 : 6.000 PSI
9 : 9.000 PSI

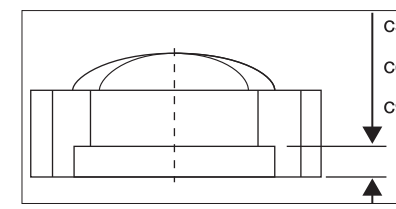

3 : 3.000 PSI
6 : 6.000 PSI
9 : 9.000 PSI

DN	GALGA	BRIDA	D3	H3	D6	H6	D9	H9
12	8	1/2"	30'2	6'7	31'8	7'8	-	-
16/20	10/12	3/4"	38'1	6'7	41'3	8'8	41'3	14'0
25	16	1"	44'5	8'0	47'6	9'5	47'6	14'0
32	20	1.1/4"	50'8	8'0	54'0	10'3	54'0	14'0
40	24	1.1/2"	60'3	8'0	63'5	12'6	63'5	14'0
50	32	2"	71'4	6'5	79'5	12'6	-	-

